

ELECTRIC DELIVERY VEHICLE

Emergency Response Guide

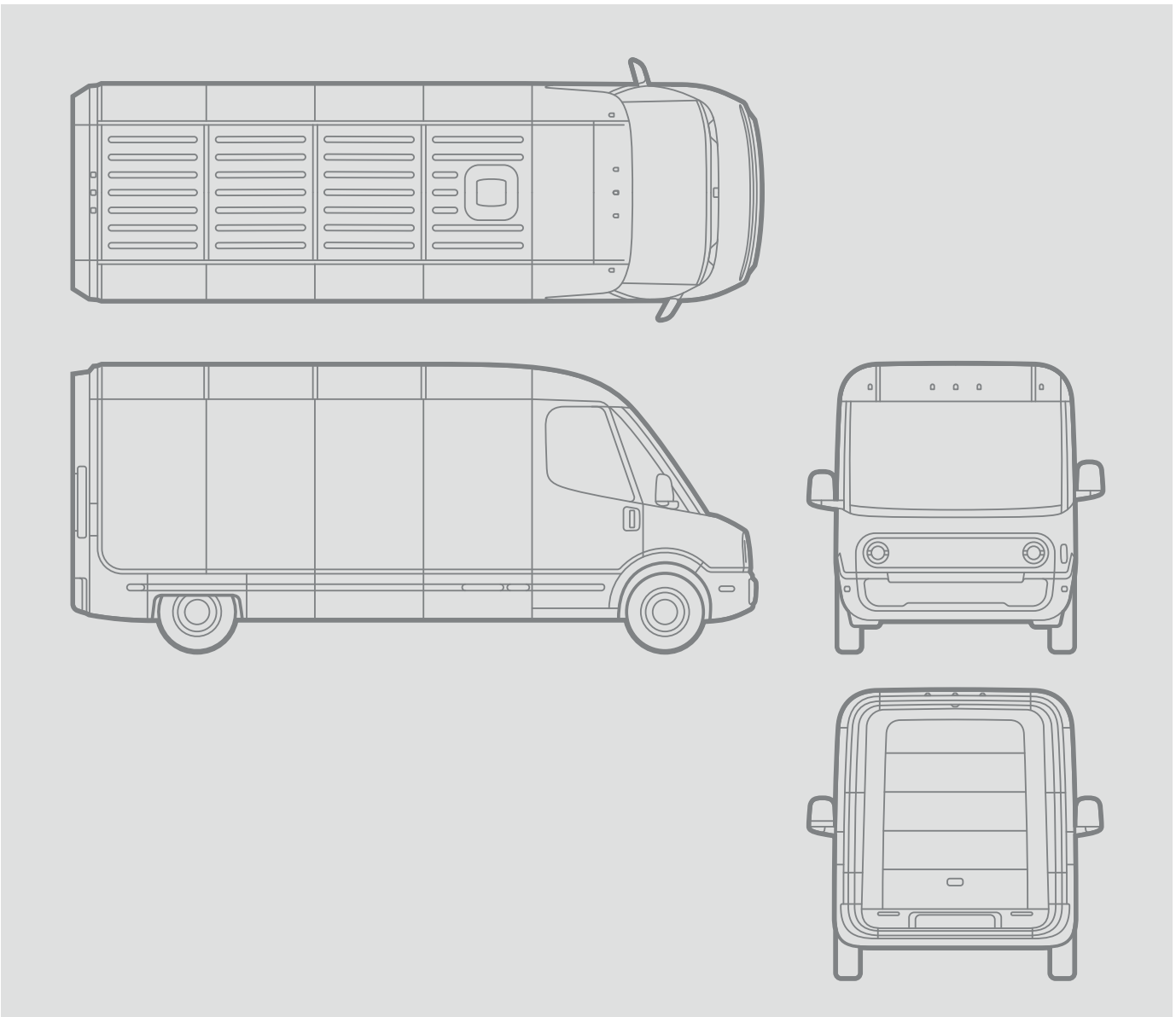



© 2021 Rivian Automotive, LLC. All rights reserved.

All information in this document and all vehicle software is subject to copyright and other intellectual property rights of Rivian Automotive, LLC, its affiliates, or its licensors. This material may not be modified, reproduced, or copied, in whole or in part, without the prior written permission of Rivian Automotive, LLC, its affiliates, or its licensors. Unless indicated otherwise, all trademarks are owned and registered by Rivian Automotive, LLC, its affiliates, or its licensors in the United States and/or other countries. Please visit <https://www.rivian.com/legal/brand> for Rivian's trademarks and service marks.

Software embedded or accessed by the vehicle may utilize open source software. Please visit <https://www.rivian.com/legal/open-source> for more information.

Contents

Summary	4
RISKS: Fire, Electrocution, and Inhalation Hazards	4
First Secure the Vehicle and Disconnect High Voltage	4
Avoid Electrocution	4
Considerations During a Rescue Operation/Extrication	4
Be Careful When Moving or Storing a Vehicle	4
Avoid High-Voltage Dangers	5
Recommended Tools for Rivian Vehicle First Responders	6
Identify Rivian Electric Vehicles	7
Secure the Vehicle	8
Chock the Wheels and Put the Vehicle in Park	8
Lift the Vehicle Safely	11
Use Safe Lift Points	11
Disconnect the High Voltage	12
Do Not Cut	16
Extricate Occupants	17
Cut High-Strength Steel	17
Handle a Damaged High-Voltage Battery	18
Extinguish a Vehicle Fire	20
Remove a Submerged Vehicle from Water	23
Recover a Submerged Vehicle	24
Recover the Vehicle	25
Prepare the Vehicle for Recovery	25
Load the Vehicle onto the Tow Truck	26
Connect to the Rear Axle for Recovery	28
Lift the Rear Wheels	29
Stop Charging in Case of an Emergency	30
Shut Down the Main Breaker	30
Remove the Charge Plug with a Key	31
Manually Release the Charge Plug	32
Store the Vehicle	33

Summary

This Emergency Response Guide provides information and suggested best practices for mitigating an emergency with a [Rivian electric vehicle](#).

RISKS: FIRE, ELECTROCUTION, AND INHALATION HAZARDS

- High-voltage lithium-ion [battery fires](#) in electric vehicles [differ from gasoline fires](#) because of the chemical reaction in the battery and [high-voltage electricity](#). Both types of fires can be very dangerous, but an electric fire may present different risks. As in gasoline vehicle fires, inhalation hazards exist from toxic and/or flammable gases.
- Always wear [personal protective equipment \(PPE\)](#), including a self-contained breathing apparatus (SCBA), and use the right tools.

FIRST SECURE THE VEHICLE AND DISCONNECT HIGH VOLTAGE

- Make sure the vehicle is [parked and secured](#) from rolling. Stabilize the vehicle if it's not upright or is on an unstable surface.
- [Disconnect the high-voltage](#) by severing either cut loop to disconnect the battery from the vehicle.

AVOID ELECTROCUTION

- Certain locations on the vehicle are [unsafe to cut](#) during a rescue operation/extrication.
- De-energize the electric circuit or disconnect any damaged or burning vehicle that is [connected to a charger](#).

CONSIDERATIONS DURING A RESCUE OPERATION/EXTRICATION

- Some [high-strength steel components](#) may require special equipment.
- Beware of [pressurized components](#) that could rupture, fail, or suddenly release during a fire.

BE CAREFUL WHEN MOVING OR STORING A VEHICLE

- Use caution when [lifting the vehicle](#) or working with [submerged vehicles](#).
- [Tow Rivian electric vehicles](#) on a flatbed only.
- After you put a fire out, [store the vehicle](#) away from other vehicles and buildings.

Avoid High-Voltage Dangers

Note the following instructions for avoiding high-voltage dangers when responding to an emergency involving a Rivian vehicle:

- Always assume the vehicle is energized.
- Never cut or damage the [Do Not Cut locations](#) on the vehicle.
- Never touch or let tools come in contact with orange high-voltage cables.
- Don't touch any other exposed parts and cables.
- Use high-voltage insulated tools if possible.
- Wear personal protective equipment (PPE), insulated gloves, and a self-contained breathing apparatus (SCBA).

Recommended Tools for Rivian Vehicle First Responders

You will need the following tools to respond to an emergency related to a Rivian vehicle:

- insulated gloves
- personal protective equipment
- wheel chocks (or large blocks of wood)
- metal circular saw
- hydraulic cutter
- hydraulic spreader
- thermal imaging camera
- halligan bar
- insulated cable cutter
- rescue stabilization jacks

Identify Rivian Electric Vehicles

Identify a Rivian Electric Delivery Vehicle by these features:

FRONT

- Round daytime running lights/parking lights

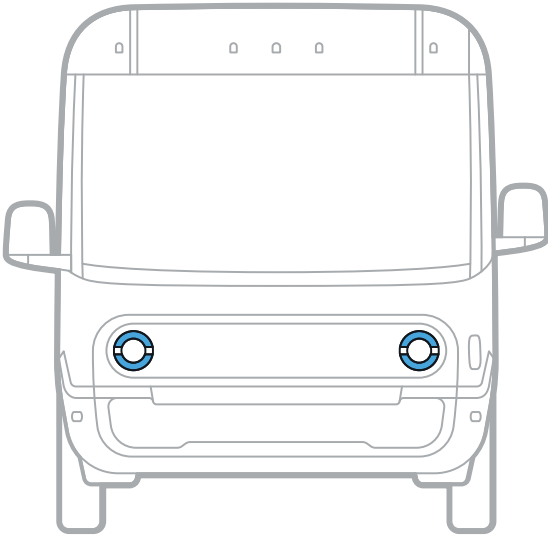

REAR

- Light bar
- No tailpipe

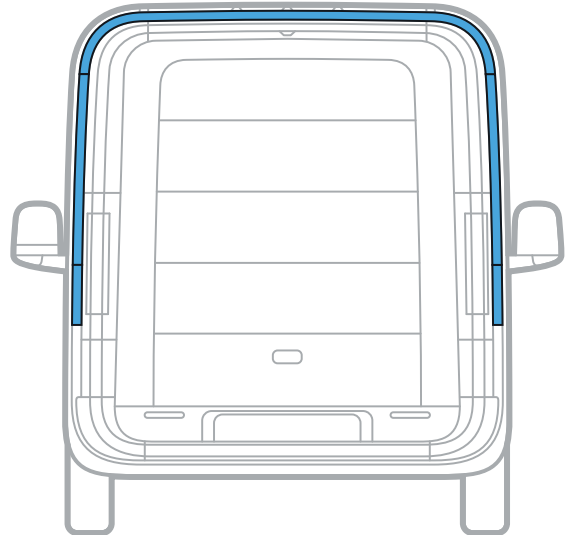

SIDE

- Rivian name on panel behind door

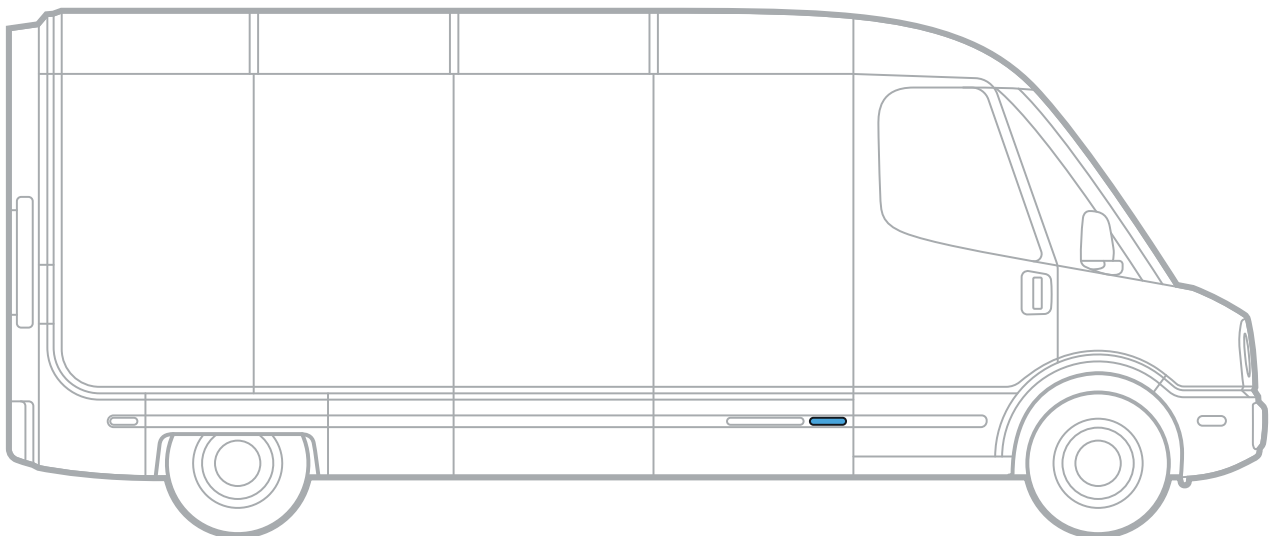

Secure the Vehicle

In an emergency, always chock the wheels, put the vehicle in **P (Park)**, and [stabilize the vehicle](#).

Rivian recommends these high-voltage insulated tools:

- wheel chocks (or large blocks of wood)
- insulated gloves
- personal protective equipment including SCBA
- rescue stabilization jacks

CHOCK THE WHEELS AND PUT THE VEHICLE IN PARK

Follow these steps to secure the vehicle.

1. Chock the wheels to prevent the vehicle from moving.

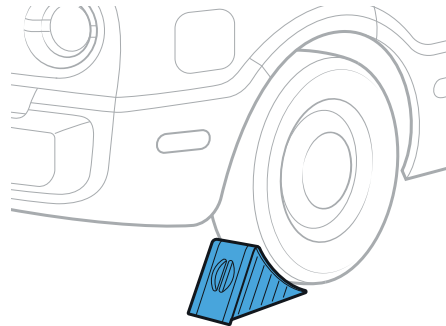

DANGER

- Electric vehicles can roll silently.
- Protect people from being hit or crushed.

2. Open the driver or curbside door. Break the glass if necessary. If you're using the inside driver door panel, press the e-release button twice. Or, pull once on the emergency release lever on the front of the armrest.

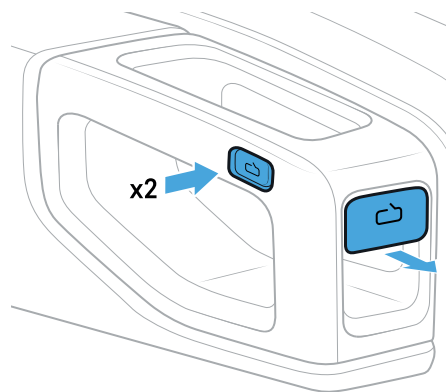

IMPORTANT

Don't press buttons on the key fob that would lock the doors.

2. Shift into **P** (Park).

Press the button on the end of the lever on the right side behind the steering wheel.

NOTE

The display shows **P** when you put the vehicle in **P** (Park).

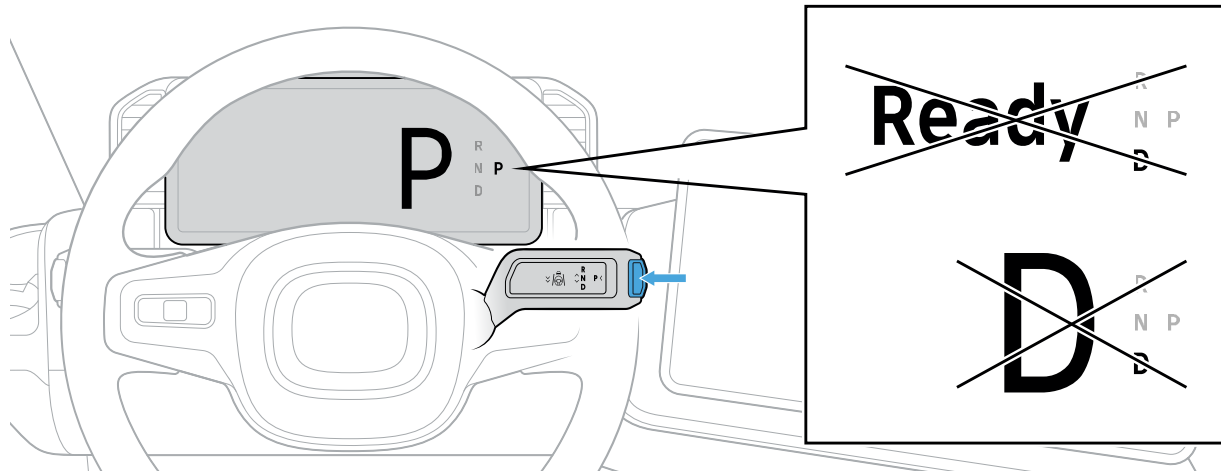

DANGER

If the display shows **Ready**, the vehicle is in high voltage on mode. Immediately press the brake and press **P** on the end of the drive stalk to shift into **P** (Park).

EMERGENCY RESPONDER INFORMATION LABEL

There is a label for emergency responders on the driver's door pillar with information on severing the cut loop and a QR code to download this Emergency Response Guide.

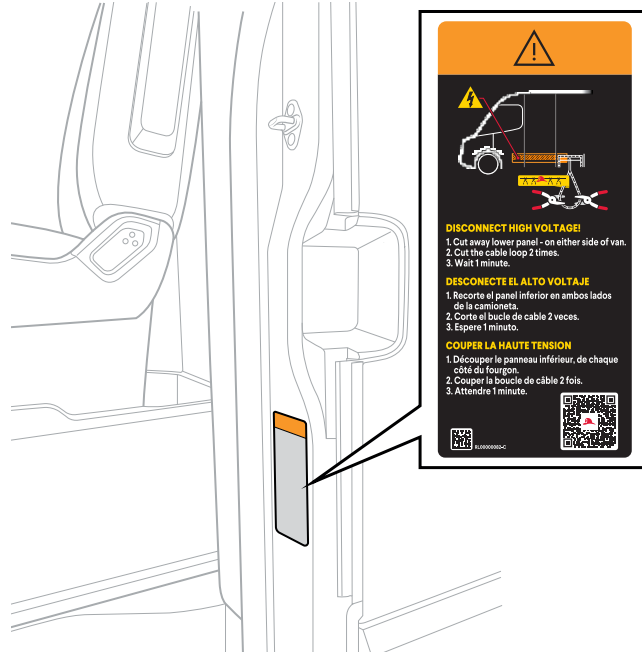

Lift the Vehicle Safely

Rivian recommends you use the following tools (high-voltage insulated) to lift the vehicle:

- insulated gloves
- personal protective equipment
- rescue stabilization jacks
- jack or other safe lifting device

USE SAFE LIFT POINTS

Lift the vehicle at these points only:

1. Underbody lift points (blue circles)
2. Front lower control arms

NOTES

The four designated lift points are the safest. There are triangles stamped on the lower body panels marking the lift point locations.

IMPORTANT

Do not use jacks or lifting equipment such as airbags under the battery pack.

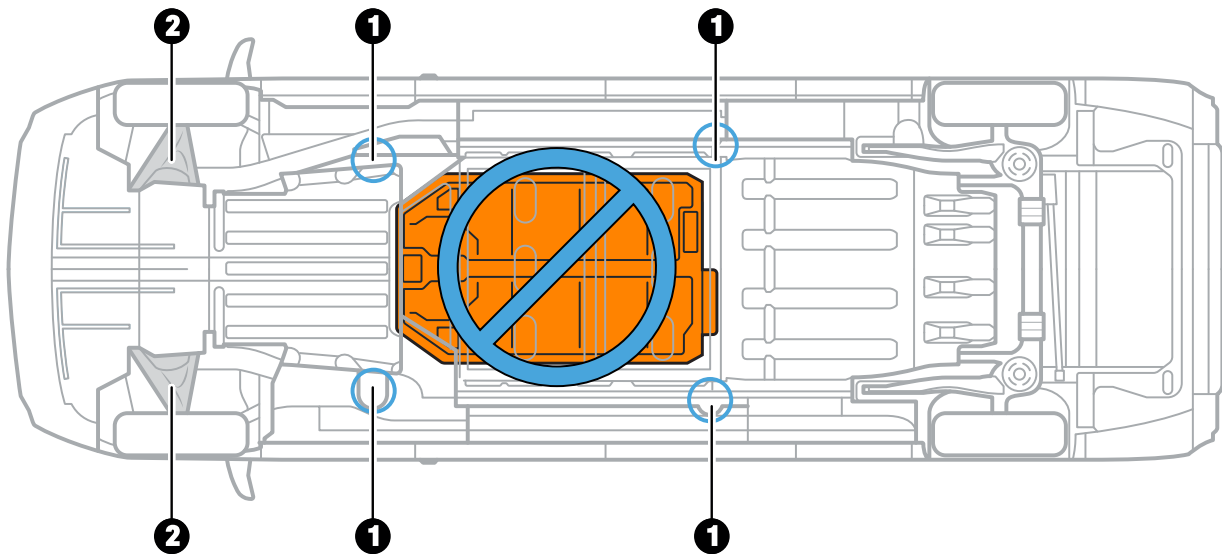

Disconnect the High Voltage

Before you attempt to disconnect the high voltage by severing a cut loop, take note of the following safety guidance:

DO

- Wear personal protective equipment (PPE) appropriate for electric vehicles.
- Use insulated tools.

Note: If an insulated tool is not available, avoid contact with the vehicle while cutting the loop.

DON'T

- Cut into or penetrate any other cables or [“Do Not Cut” locations](#).
- Touch any electrical cables.
- Touch electrical or battery components.

DON'T ATTEMPT IF

- [Cut loop \(low-voltage\) cables](#) are inaccessible and can't be easily cut.
- Vehicle is on fire.
- Vehicle is in standing water or is submerged.
- You see a sign of potential fire, such as
 - sparks
 - detached cables
 - increased temperature
 - smoke or smell
 - hissing, gurgling, or bubbling
 - leaking fluid

DISCONNECT THE HIGH VOLTAGE BY CUTTING A CUT LOOP

There are two cut loop locations along the side of the vehicle. The cut loops are low-voltage circuits that enable power from the high-voltage battery and supplementary restraint system (SRS). Cutting either loop disconnects both the high voltage battery and the SRS systems within one (1) minute.

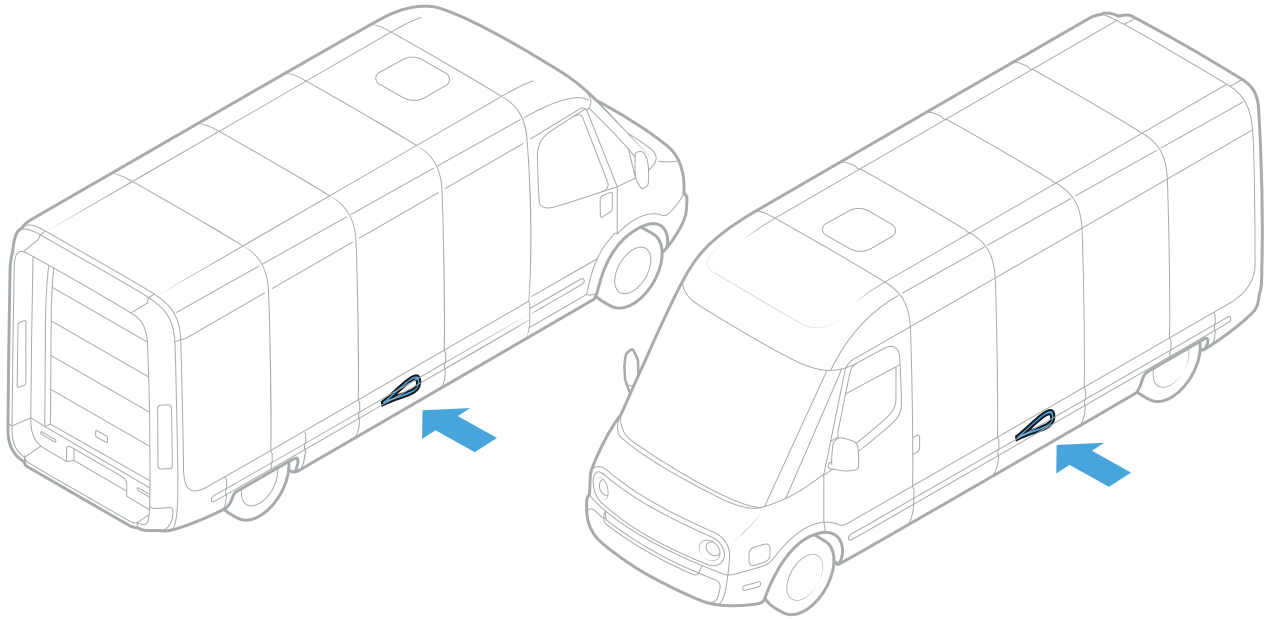

DISCONNECT HIGH VOLTAGE

Rivian recommends you use the following tools (high-voltage insulated) to cut the cut loop to disconnect high voltage on the side of the vehicle:

- insulated gloves
- personal protective equipment
- halligan bar
- insulated cable cutter

To disconnect the high-voltage cable, follow these steps:

1. Locate the lower side panel along either side of the vehicle. Look for the stamped firefighter hat.

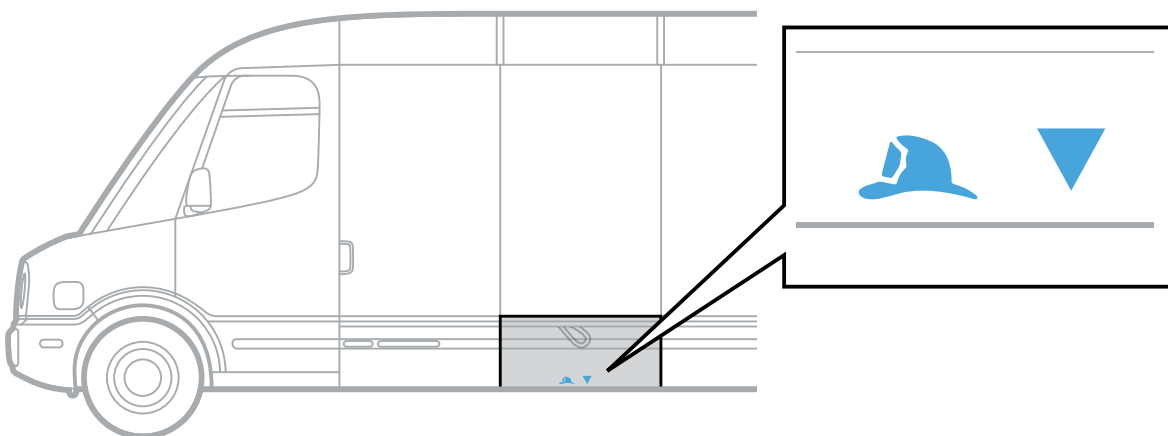

2. Use a halligan bar to pry off the panel to expose the cut loop.

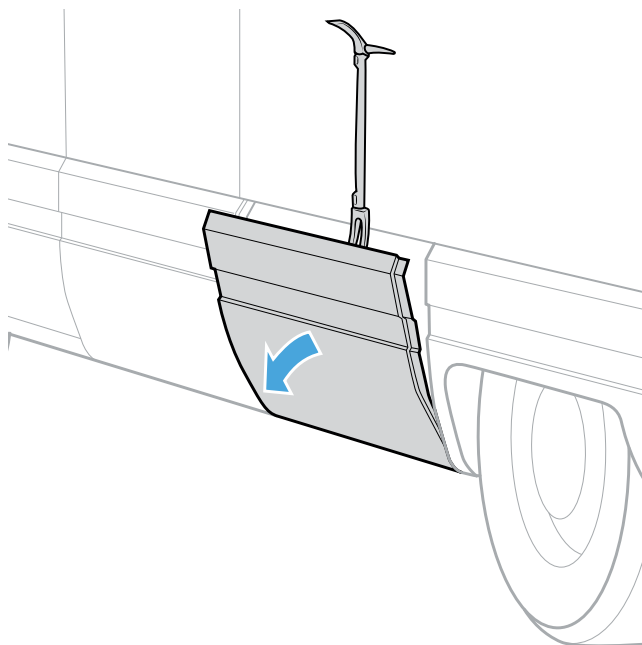

DISCONNECT THE HIGH VOLTAGE

- Find the loop of electrical cable with the yellow cut tag. Cut the loop at one end [1] and at the other end [2].



When you cut in two places and remove a section of the cable, it helps prevent the ends of the cable from touching again. If the ends of the cable touch, it could restore high voltage, which could result in death.

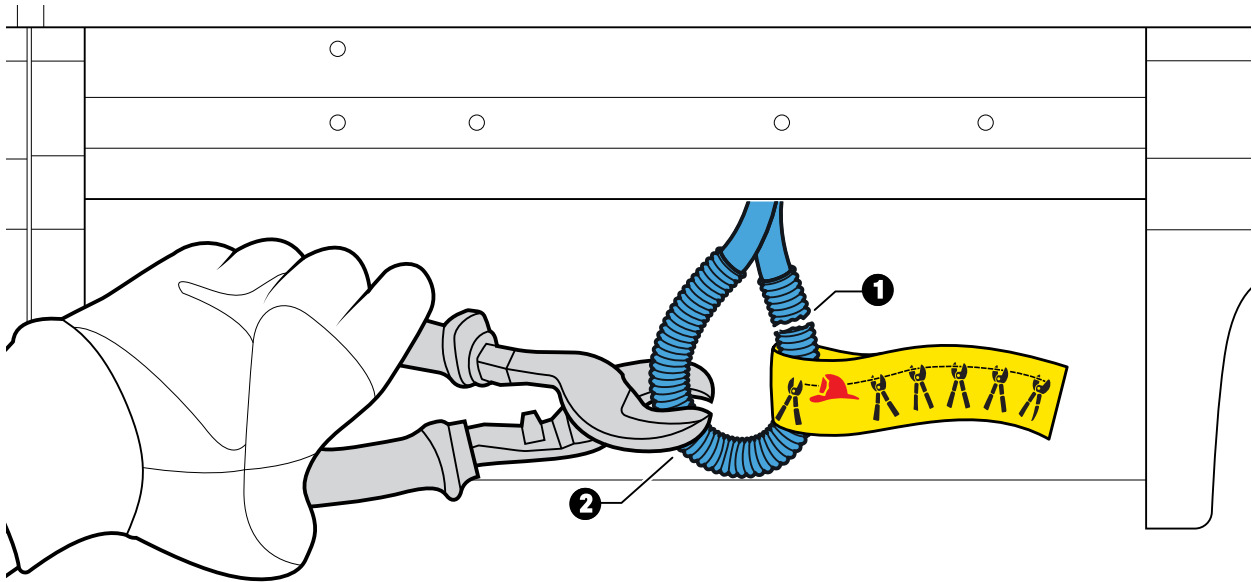

- Wait one minute to allow the airbags and seat belt system to discharge any remaining energy.

Do Not Cut

Never cut or damage the highlighted areas.

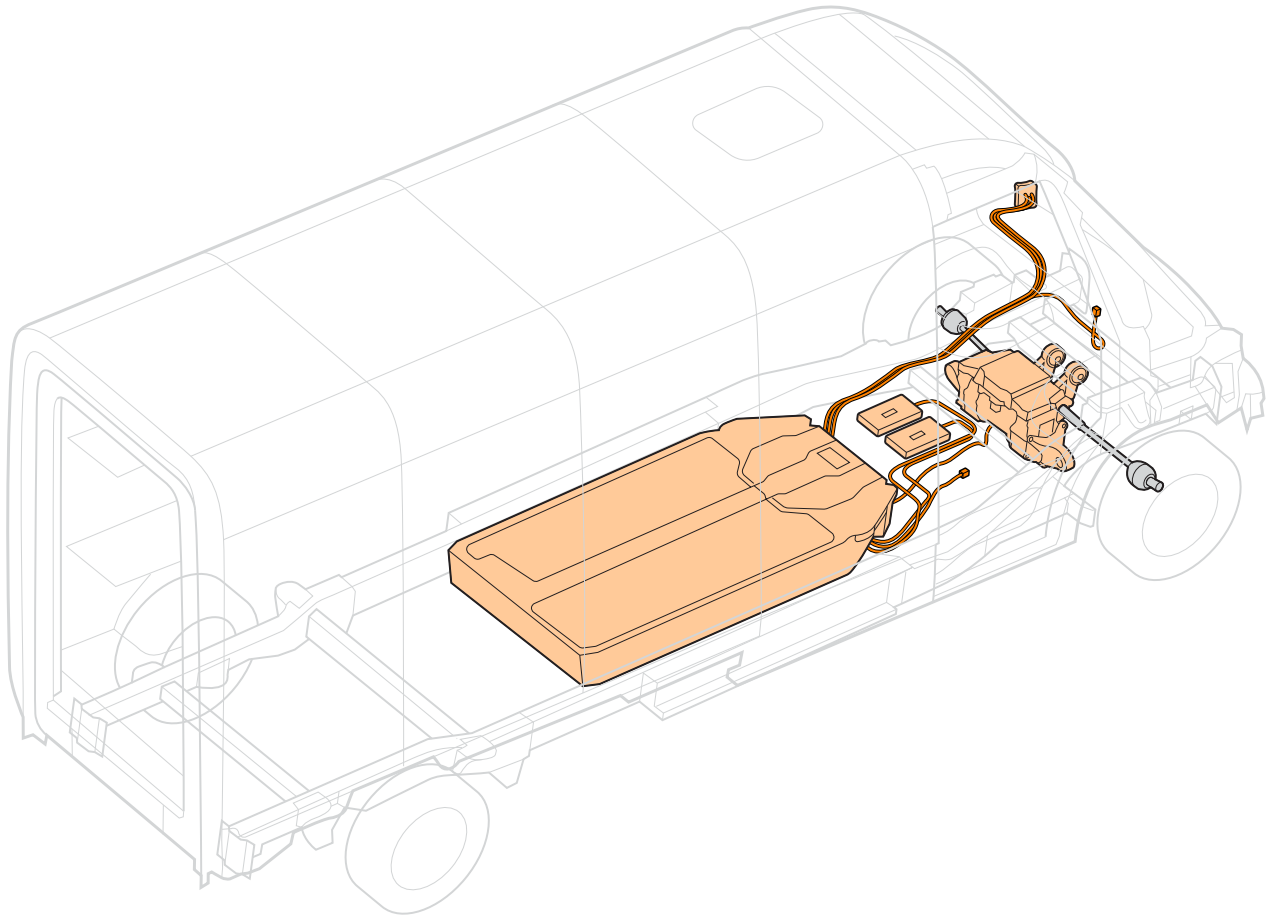

DANGER

- You could be injured, electrocuted, or die if you cut, pierce, or damage the highlighted areas.
- These areas contain lithium-ion battery packs, high-voltage cables (up to 450 V), traditional car batteries (12 V), compressed gas, and triggering devices.

Extricate Occupants

Rivian recommends you use the following tools (high-voltage insulated) to extricate occupants:

- insulated gloves
- personal protective equipment
- hydraulic cutter
- hydraulic spreader
- metal circular saw

CUT HIGH-STRENGTH STEEL

The highlighted areas contain high-strength steel to protect passengers. Use a hydraulic cutter to cut these areas. Cutting through this material may take longer than expected.

Wear insulated gloves and personal protective equipment (PPE) when cutting high-strength steel.

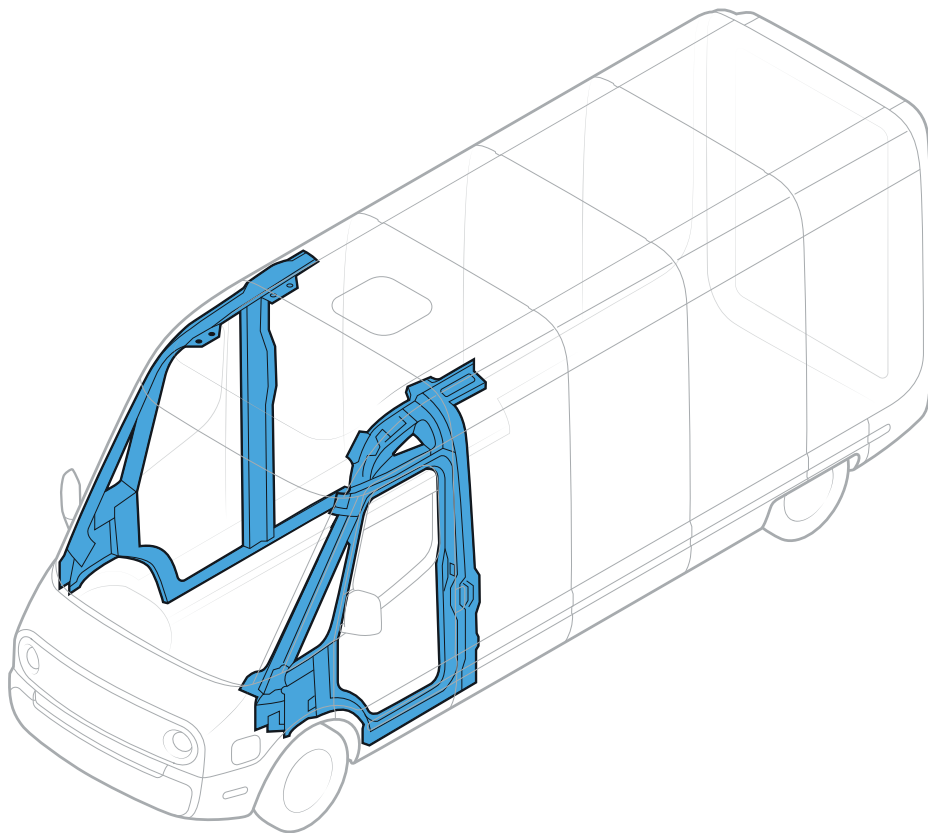

DANGER

Never cut or damage the Do Not Cut areas.

Handle a Damaged High-Voltage Battery

Rivian vehicles use a lithium-ion high-voltage battery (up to 450 V) and high-voltage cable next to the axles.

In case of fire, do not cut the battery or cables in an attempt to cool it down.

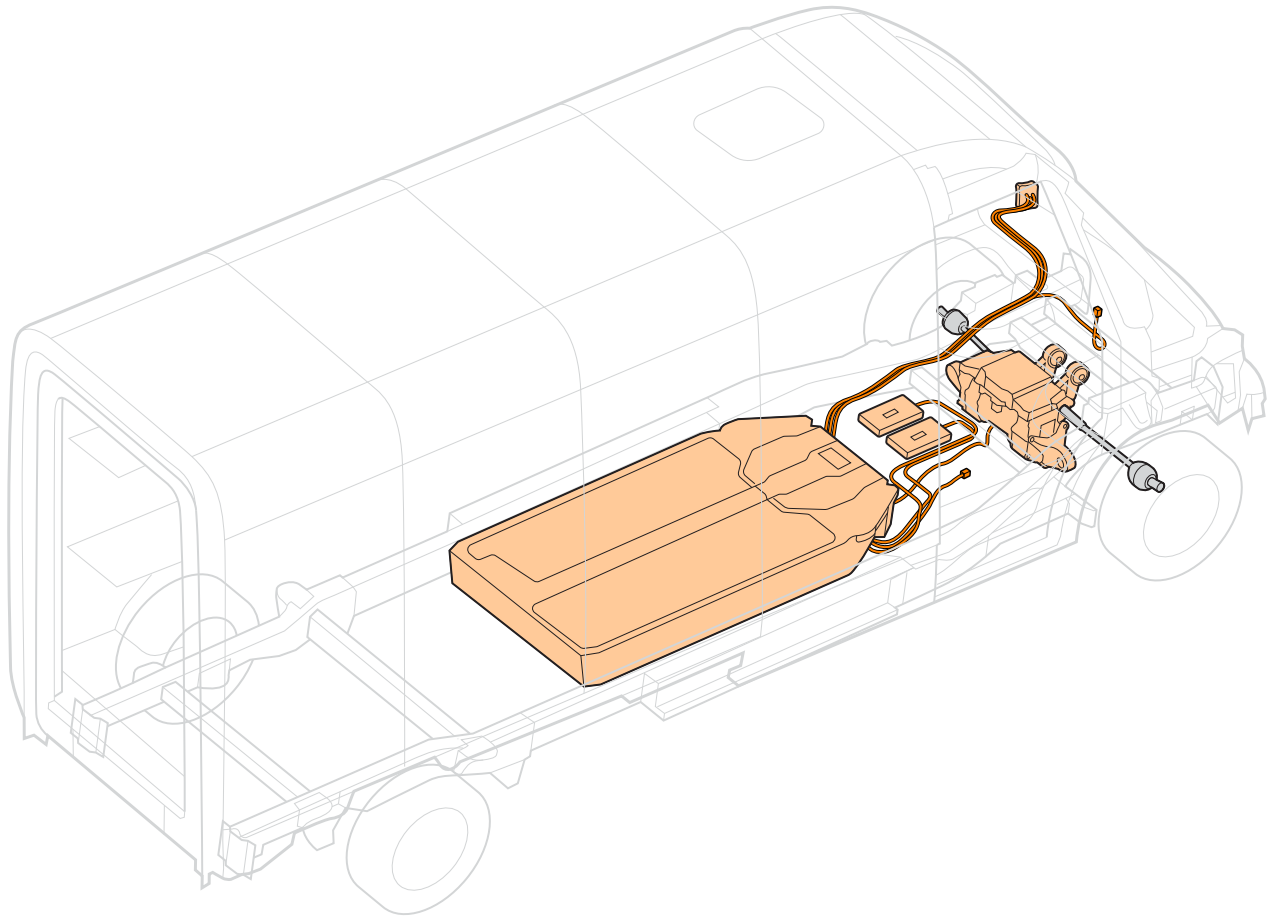

A damaged battery poses a potential electrical hazard that could release harmful and/or flammable gases.



DANGER

The flammable gases that leak from the battery could ignite.

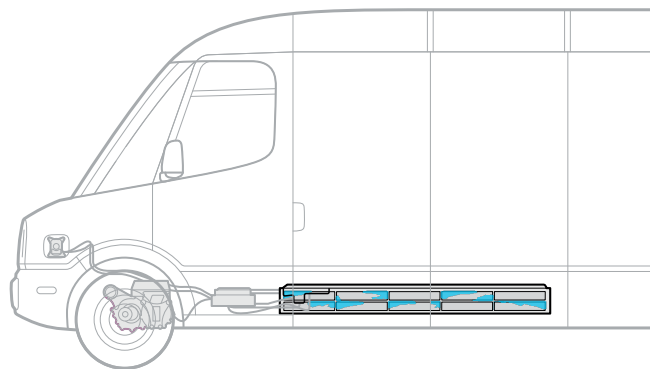

HANDLE A DAMAGED HIGH-VOLTAGE BATTERY

After a fire, clean up with large volumes of clean water before using chemicals.

To prevent runoff into nearby storm drains or other waterways, you may deploy fluid gathering materials such as booms or powders to limit runoff contamination.

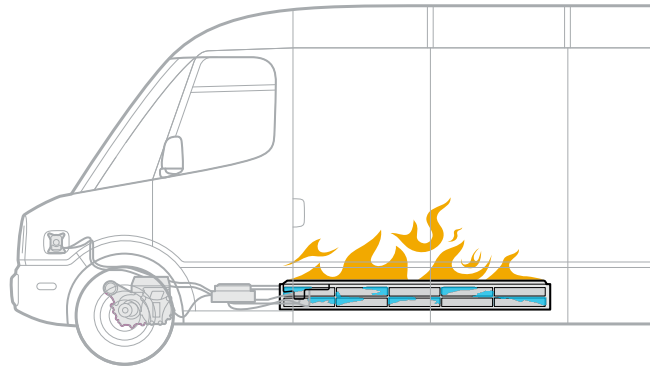

DANGER

Water applied to the battery pack can become caustic or could cause a chemical reaction and burn the skin. To prevent burns, apply more water for dilution. Rinse tools and clothing to decontaminate them.

Extinguish a Vehicle Fire

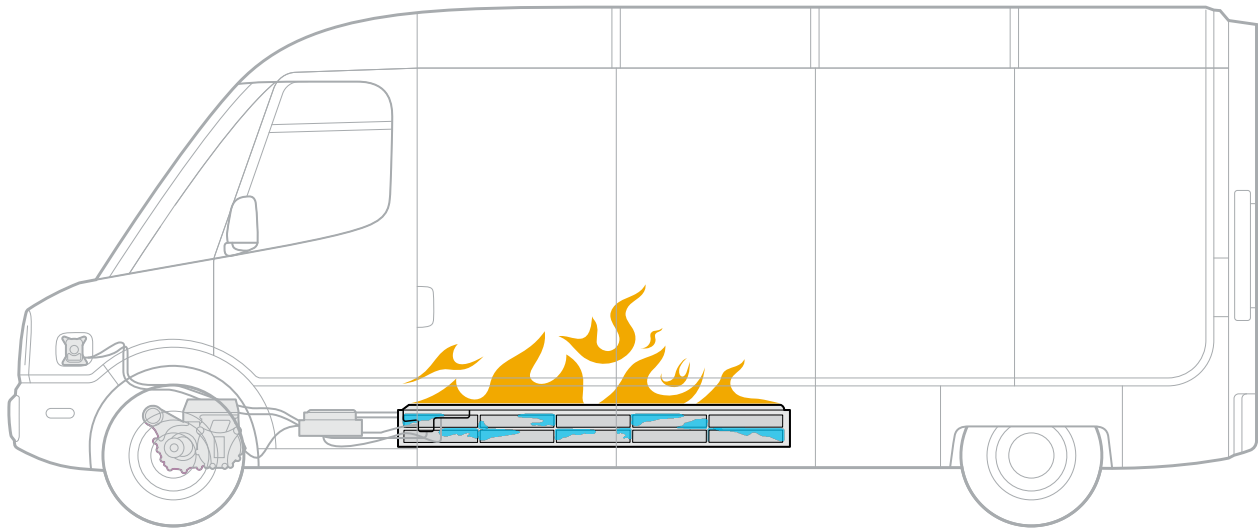

IMPORTANT

Rivian believes that electric vehicle fires are best addressed with defensive firefighting and management of the environment to minimize risk. Only attempt to extinguish a fire if you have a specific need to do so.

Perform these steps to extinguish a vehicle battery fire.

1. Wear proper personal protective equipment (PPE) with full SCBA when approaching any vehicle fire.
2. Use a sustained, high-volume water application. 2,000-3,000 gallons minimum will be needed. Consider an established water supply, a tender, or additional units to shuttle water to the pumping engine.
3. If water is not readily available, use defensive firefighting tactics to prevent the fire from spreading until a clear need to extinguish the fire is identified and water is available. If necessary, use CO₂, dry chemicals, or other fire-extinguishing agents to suppress the fire, for example, to extricate passengers, until water is available.
4. Use a thermal imaging camera (TIC) or infrared (IR) to monitor the battery temperature during the cooling process. Look for ambient temperatures at or below 212°F (100°C). The battery still needs to cool down if it is at or above 302°F (150°C).
5. Continue evaluating the battery structure and apply water directly to any exposed areas. Submerge loose battery cells or modules in water for at least 24 hours.

IMPORTANT

- Only firefighters should extinguish a high-voltage battery fire.
- Use a hand-held extinguisher only to protect occupants as they exit the vehicle or for small fires that don't involve the high-voltage battery.
- Foam may suppress, but will not extinguish a battery fire.

SUDDEN RUPTURE RISKS

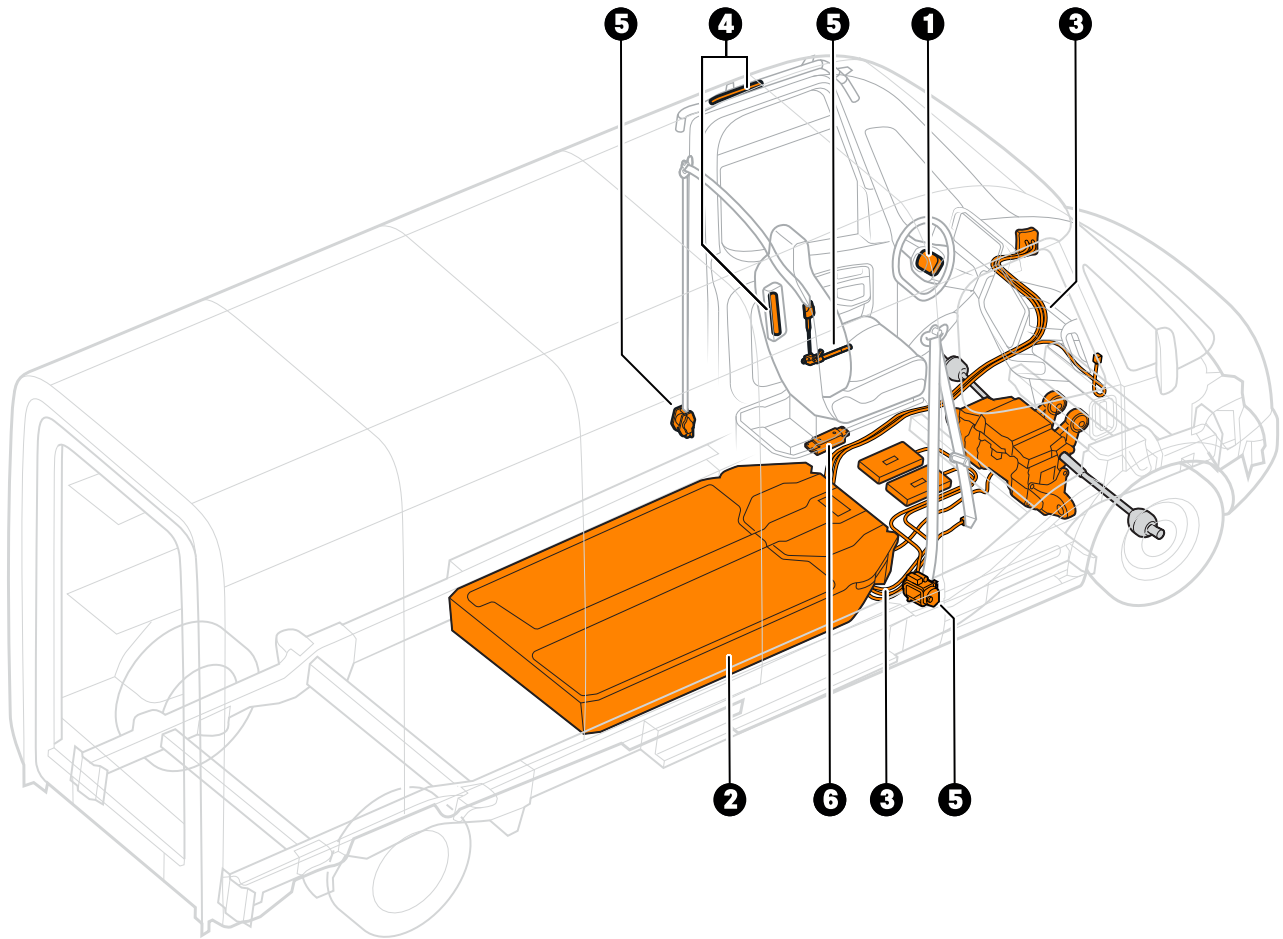

- | | |
|-------------------------|----------------------------|
| 1. Airbag | 4. Gas inflation cylinders |
| 2. High-voltage battery | 5. Seat belt pretensioners |
| 3. High-voltage cable | 6. HV pyro switch |

NOTE

It's safe to use water to put out the fire on a Rivian vehicle because of the properties of current flow and voltage. Undamaged high-voltage electrical systems are normally isolated from the chassis.



DANGER

- Do not cut the battery. This can cause injury, electrocution, or death.
- The lithium-ion battery packs are high-voltage (up to 450 V).
- An undetected fire can remain inside the high-voltage battery.

Remove a Submerged Vehicle from Water

Rivian recommends that you wear personal protective equipment (PPE) when removing the vehicle from water.

Always remove a submerged vehicle from water before you attempt to [tow or transport](#) it.

For safety, don't try to recover a submerged vehicle from the water by yourself—get help.

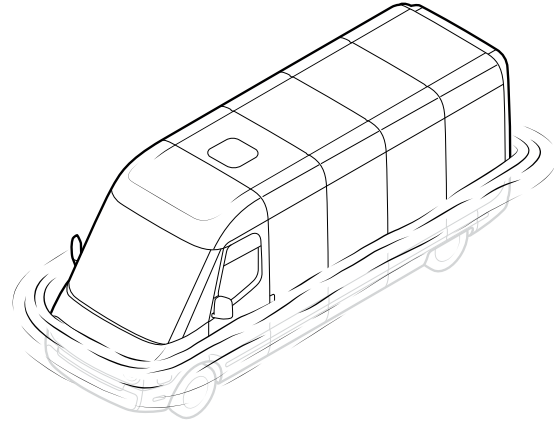

- If the battery is damaged, water may have entered the battery case. Use extreme caution and wear personal protective equipment (PPE) if you enter the water or attempt to tow the vehicle.
- Never attempt to charge a high-voltage battery that has been submerged, is gassing, or exhibits signs of external damage.

RECOVER A SUBMERGED VEHICLE

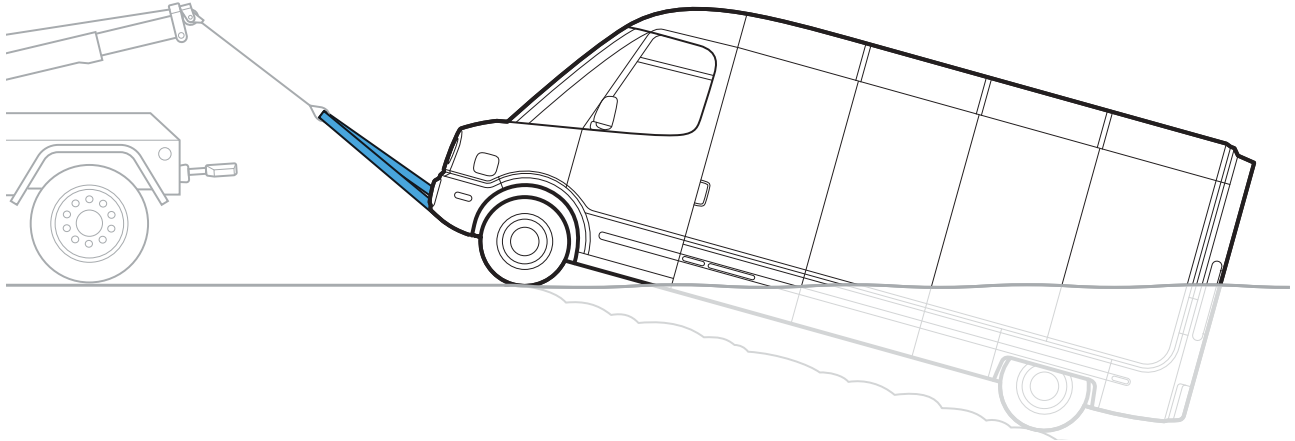

You may see small bubbles in the water near the vehicle (microbubbling). This isn't a sign that the water is electrified or will cause a shock.



DANGER

When handling an emergency, always approach an electric vehicle from the side. Electric vehicles can run silently, and a damaged high-voltage battery can remain energized, allowing the vehicle to move unexpectedly.

Recover the Vehicle



Only transport the vehicle on a flatbed tow truck. To prevent damage, don't tow the vehicle behind another vehicle or with two wheels on the ground.

Be aware of overhead clearance limits. The vehicle height is 9 ft 3.2 in (2.83 m).

PREPARE THE VEHICLE FOR RECOVERY

1. Ensure the front wheels face forward and are parallel with the vehicle.
2. Put the vehicle in **P** (Park) and chock the wheels.
3. Connect the vehicle to the tow truck winch with a nylon bridle or short endless loops through the lower control arms.



To prevent damage, don't use J-hooks to connect to any suspension components.

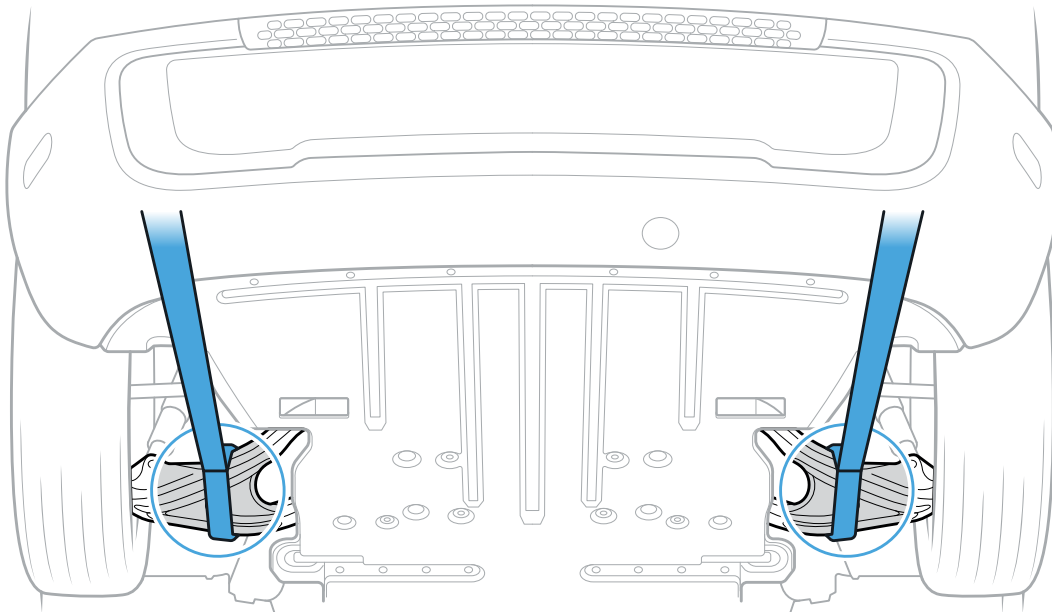

4. Press and hold the brake pedal.

RECOVER THE VEHICLE

5. In the center display, go to **Safety**. Turn on **Park brake release**. Choose **Start Release**.

NOTE

The park brake release will turn off after 15 minutes. You can also turn it off by putting the vehicle in **P** (Park) or turning off **Park brake release** under **Safety** in the center display.

6. Release the brake pedal and confirm release of the electronic park brake.

You can now [load the vehicle](#) onto the tow truck.

LOAD THE VEHICLE ONTO THE TOW TRUCK

1. Ensure the **Park brake release** is turned on.
2. Remove the wheel chocks.
3. Use the tow truck winch to pull the vehicle onto the tow truck deck.

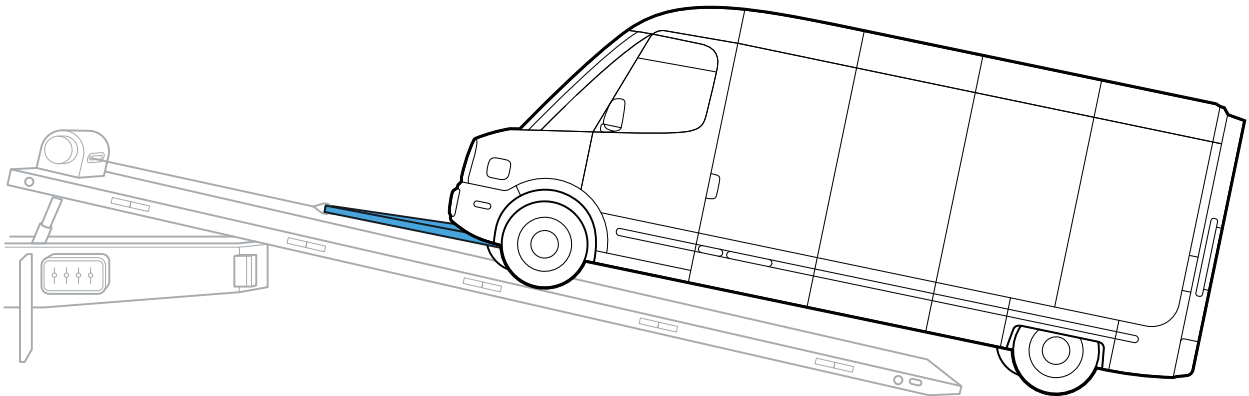

4. Pull at 5 mph (8 km/h) or less to prevent damage to the drive train.

NOTE

If you pull too fast, the vehicle will stop and return to **P** (Park).

RECOVER THE VEHICLE

5. Tie down the vehicle using eight-point retention straps with two points of contact per corner.

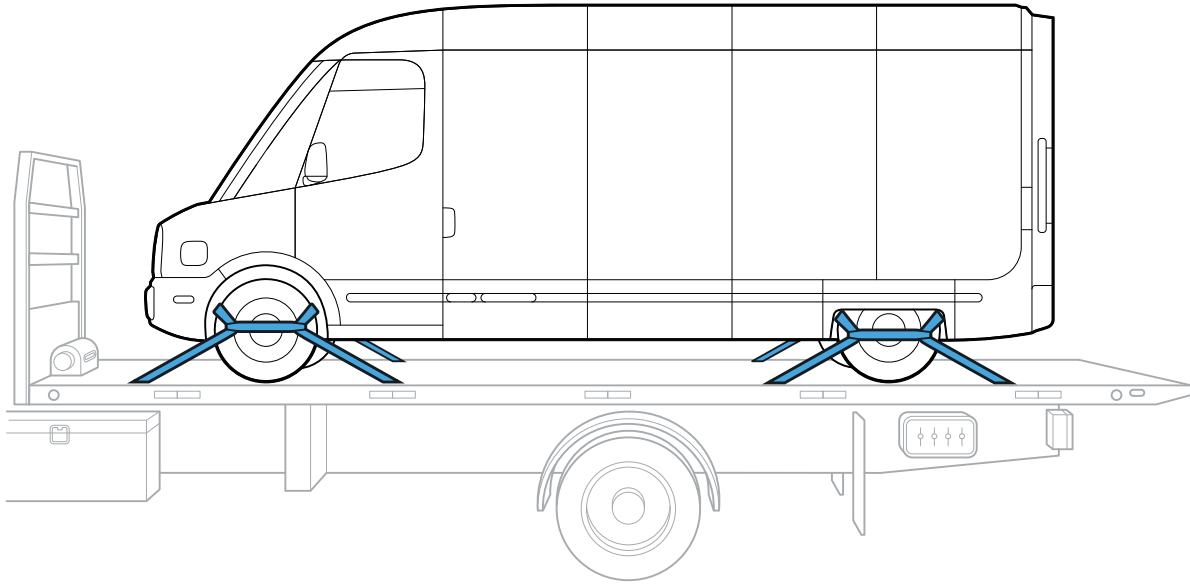

CAUTION

To prevent damage, ensure the straps don't contact the brake lines behind the tire.

6. Put the vehicle into **P** (Park).

CONNECT TO THE REAR AXLE FOR RECOVERY

If you can't connect to the front control arms, you can recover the vehicle using the rear axle.

1. Ensure the front wheels face forward and are parallel with the vehicle.
2. Put the vehicle **P** (Park) and chock the wheels.
3. Connect the vehicle to the tow truck winch with a nylon bridle or short endless loops through the rear axle.



To prevent damage, don't use the tow eye or rear bumper step to connect to the tow truck.

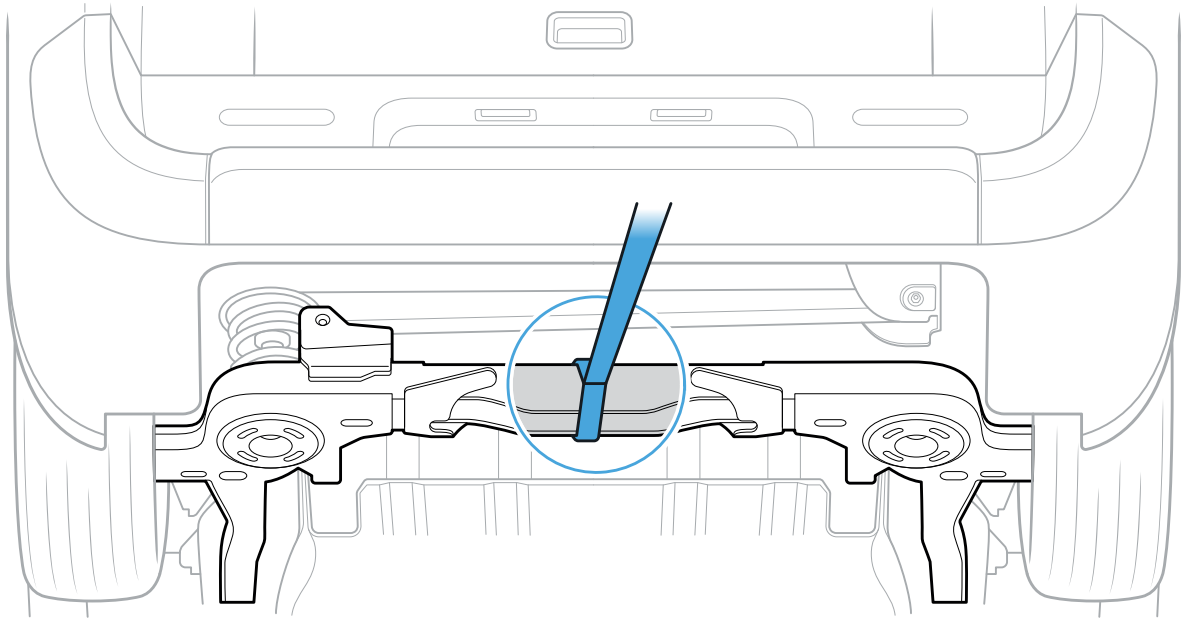

4. Press and hold the brake pedal.
5. In the center display, go to **Safety**. Turn on **Park brake release**. Choose **Start Release**.

NOTE

The park brake release will turn off after 15 minutes. You can also turn it off by putting the vehicle in **P** (Park) or turning off **Park brake release** under **Safety** in the center display.

6. Release the brake pedal and confirm release of the electronic park brake.

LIFT THE REAR WHEELS

If you can't release the electronic park brake, you can load the vehicle onto the tow truck by lifting the rear wheels.



DANGER

When the rear wheels are lifted, the front wheels can roll. Make sure to secure the vehicle and connect to the tow truck before lifting the rear wheels.

1. Chock the front wheels to secure the vehicle.
2. Connect the vehicle to the tow truck using an endless loop through the front control arms or rear axle.
3. Lift the rear wheels using skates, a dolly, or a tow truck wheel lift.

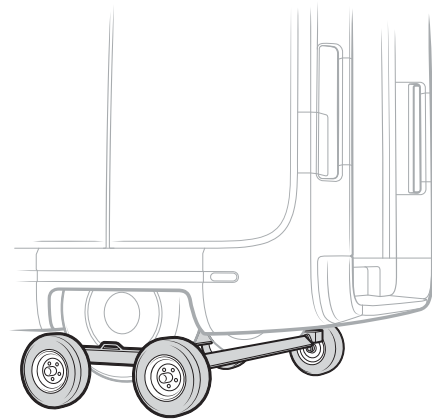
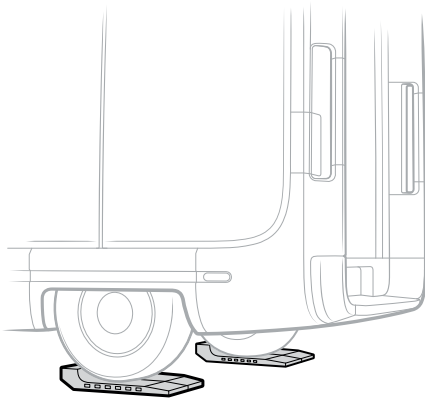

4. With the rear wheels off the ground, position the vehicle for loading onto the tow truck bed.

You can now [load the vehicle](#) onto the tow truck.

Stop Charging in Case of an Emergency

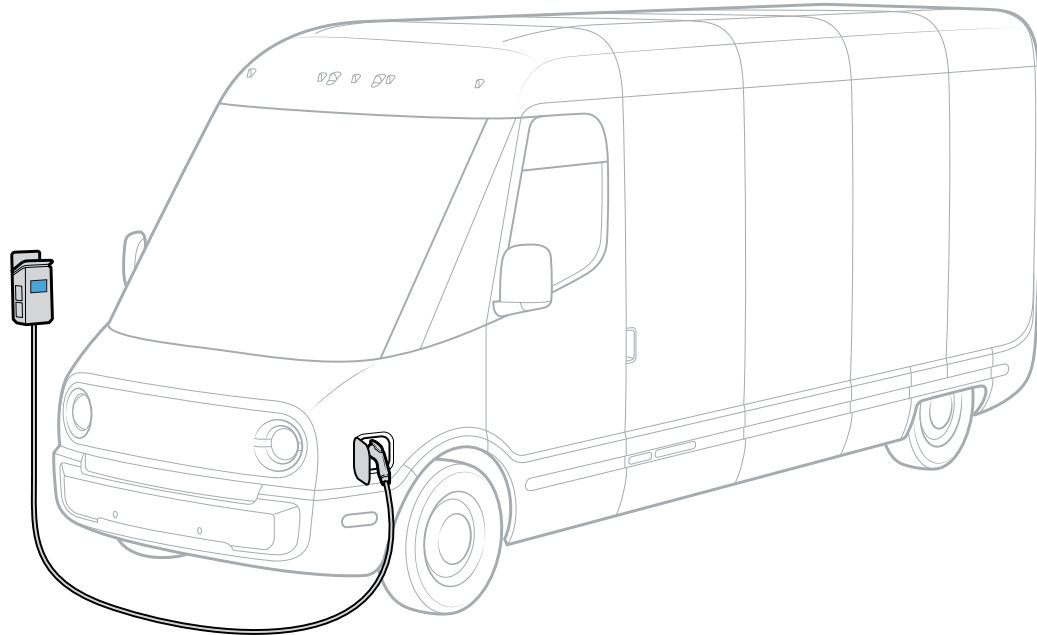

If a vehicle is damaged or on fire while connected to a charger during an emergency, the safest thing is to turn off the electricity. Shut down the main breaker for the charger and then inspect the situation. If a vehicle is damaged and at risk of a fire, you can attempt to disconnect the charging cable from the vehicle.

IMPORTANT

A Rivian vehicle includes software that automatically senses battery issues and shuts off charging. However, if the fire is not battery related or the vehicle continues charging, try the charge plug disconnection procedures below.

SHUT DOWN THE MAIN BREAKER

Use the main breaker to shut down the power to the charger. It's normally in the line of sight from the charger.

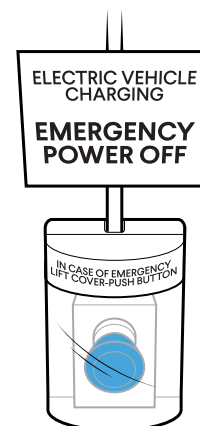

REMOVE THE CHARGE PLUG WITH A KEY

Follow these steps to remove the charge plug:

1. Unlock the vehicle.
2. Remove the charge plug from the socket and place it on the charger.

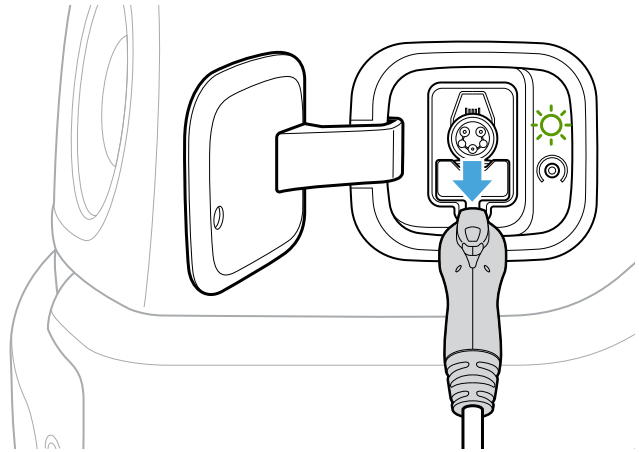

DANGER

Do not cut the charging cable. You never want to interrupt a high-voltage current flow. Doing this could cause injury, electrocution, or death.

MANUALLY RELEASE THE CHARGE PLUG

If the charge plug won't release from the charge port after you stop a charge session, manually release it by following these steps:

1. Remove the center trim panel above the tire on the driver side of the vehicle.

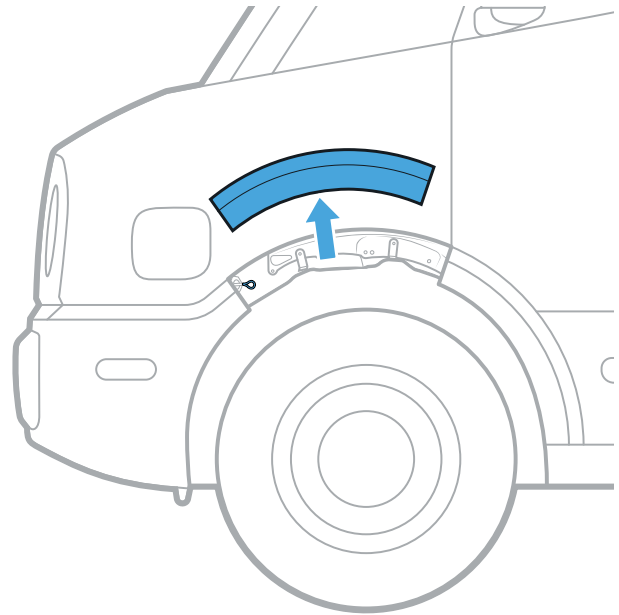

2. Gently pull the cable to release the charge plug.
3. Remove the charge plug from the charge port.
4. Replace the trim panel.

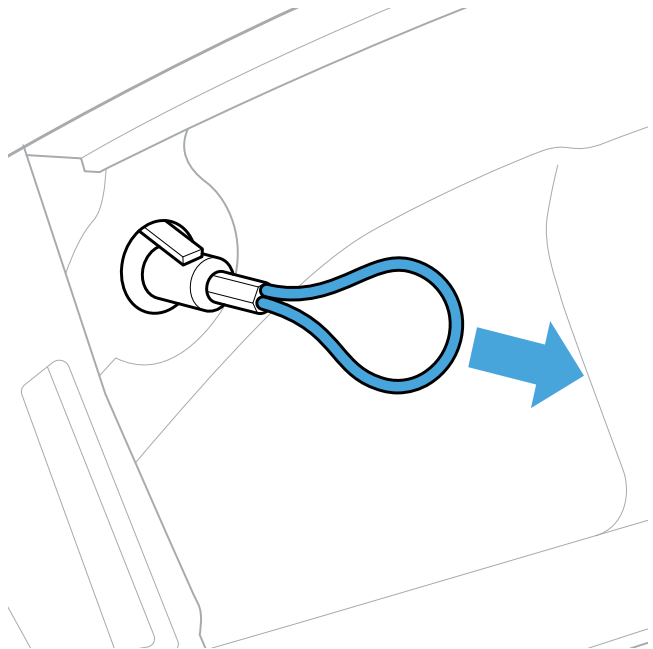

Store the Vehicle

Be careful when storing a damaged Rivian electric vehicle after an accident or fire. Be sure to [secure it when you park it](#).

1. Use signage or some other visual indicator to identify it as an electric vehicle.

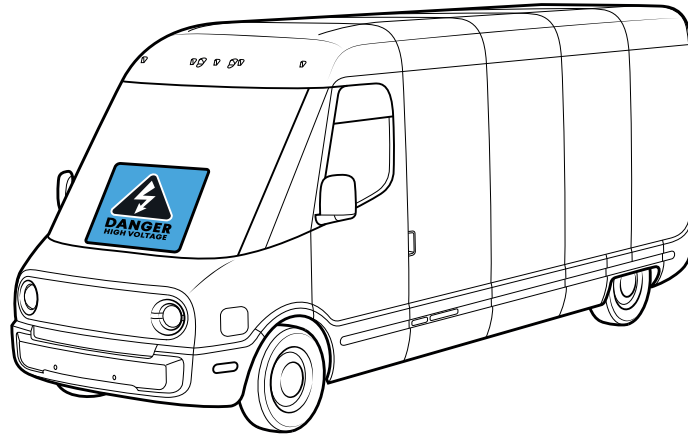

2. Store the vehicle outside at least 50 ft away from other vehicles, structures, or combustible material.

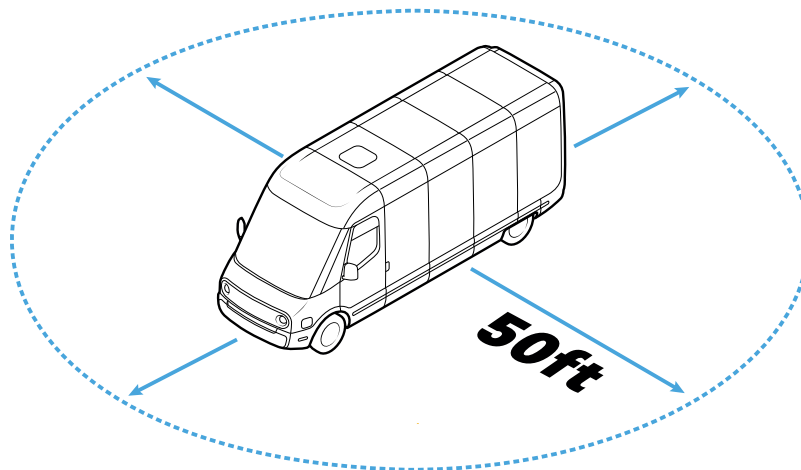

NOTE

If this spacing can't be achieved, place the vehicle where it can quickly be towed or winched away. Consider access for fire personnel, fire apparatus, and a water supply and leave space for fire personnel to periodically and quickly reassess with thermal imaging.

3. Notify others that the vehicle is on the property and ask them not to interact with it unless authorized.
4. Monitor a vehicle with a [damaged high-voltage battery](#) for signs of gas emissions, fire, or any potential issues from a leak.

STORE THE VEHICLE

5. Rivian recommends creating a tape barrier around the vehicle in an isolated area of the lot.

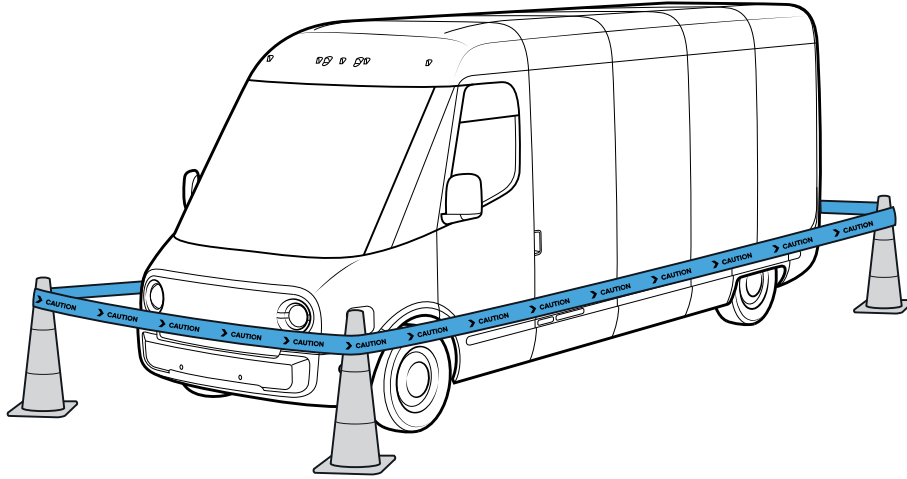

Energy that remains in a battery is especially concerning if the high-voltage components or battery are damaged. Exposed wiring and parts can also create an electrical safety hazard.